

ELT-EZD-.501x.750-1 ZipBushing™ Precision Threaded Locator Bushing

The ZipBushing™ Precision Threaded Locator Bushing from Elijah Tooling, Inc. (ELT) is a patent-pending product developed as a combination replacement of bushing and threaded insert which together make up a multi-purpose hole (MPH). The multi-purpose hole is used in modular fixturing to provide location and holding capability by multiple means. Typically a bushing is co-axially aligned with a threaded insert to facilitate the use of dowel pins, XZertz™ retractable dowel pins or shoulder screws for locating purposes, and screws, bolts, and similar for holding purposes. (In some situations, it is desirable to hold and locate at the same time, made possible via precision dowel screws - shoulders screws).

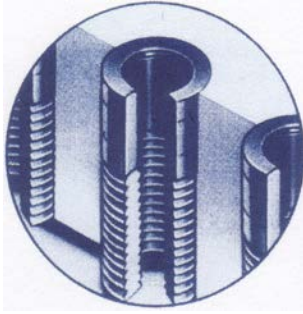

The advantage of the ZipBushing™ Precision Threaded Locator Bushing is that all of the holding and locating capability is supplied via one product, not two. Not only does it consist of one unified product, but it is easily installed, by turning; or removed, by turning, using the EZE-DRIVE™ feature (10 point star driver). The installation and removal of regular bushing and insert combinations is significantly more difficult. Thus, the "ZipBushing" quickly facilitates the initial installation or repair and replacement of damaged holes. When plates require skimming marring and scarring, this product will make it possible to enhance the depth of the hole for multiple passes on the plate.

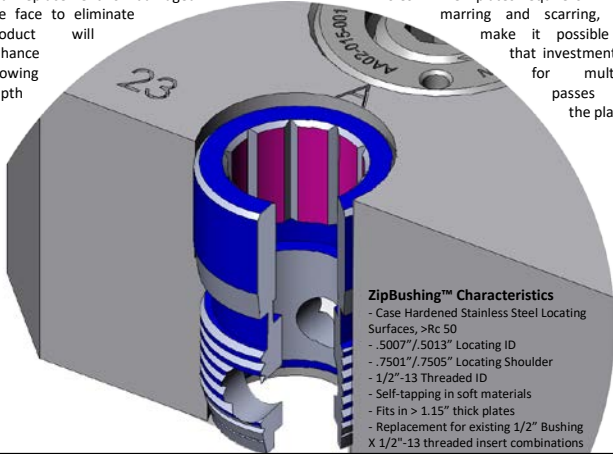

- ZipBushing™ Characteristics**
- Case Hardened Stainless Steel Locating Surfaces, >Rc 50
 - .5007"/.5013" Locating ID
 - .7501"/.7505" Locating Shoulder
 - 1/2"-13 Threaded ID
 - Self-tapping in soft materials
 - Fits in > 1.15" thick plates
 - Replacement for existing 1/2" Bushing X 1/2"-13 threaded insert combinations

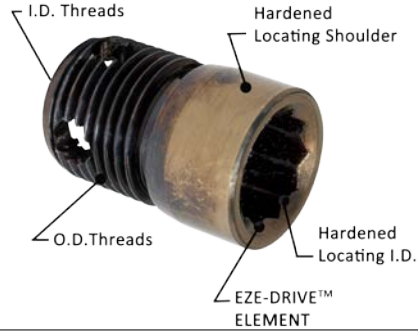

OPERATING INSTRUCTIONS

- 1 Prepare the receiving plate in the following manner:**

 - Drill a 41/64" (16.27mm) diameter to a depth of at least 1.22" (31mm). It is preferable to produce a through hole, but not necessary. *If self-tapping option is desired, and depending upon method used & torque applied, a larger hole may be necessary. Up to 17.5mm will work.*
 - Counter Bore .7507/.7510" (19.07mm) to a depth of at least .48" (12.2mm)
 - Countersink .78" (19.8mm) x 90 degrees
 - Tap or Thread M18x1.5 to a minimum depth of 1.13" (28.7mm). *(Optional if self-tapping option is desired.)*
- 2 Install ZipBushing™ Precision Threaded Locator Bushing**

 - Apply medium duty thread locker to the outside threads.
 - Place "ZipBushing" into prepared hole.
 - Insert ELT-EZD-DRIVER-1 drive mechanism into the drive element (10 star pattern) of the bushing.
 - Using PRO-1 torque limiting pneumatic wrench (orequivalent), at the # 2 torque setting, applying approximately 35 ft.lbs. force, to screw bushing clockwise until it bottoms in the hole.
- 3 Remove ZipBushing™ Precision Threaded Locator Bushing**

 - Insert ELT-EZD-DRIVER-1 into the drive element of the product.
 - Using PRO-1 torque limiting pneumatic wrench (or equivalent), at the # 4 torque setting, apply approximately 65 ft.lbs. force, screwing counter-clockwise until the product is out.



Driver

USE ZIPBUSHING™ PRECISION THREADED LOCATOR BUSHING WITH: 1/2" LOCATING SHOULDER PRODUCTS, SUCH AS XZERTZ™ RETRACTABLE DOWEL PINS, DOWEL PINS OF MANY TYPES, SHOULDER SCREWS ETC.; 1/2"-13 SCREW PRODUCTS SUCH AS SOCKET HEAD CAP SCREWS ETC.

ZipBushing™ Precision Threaded Locator Bushing
P/N: ELT-EZD-.501x.750-1
.501" ID x .750" x 1.125" OAL



LIMITED WARRANTY: We warrant that within 90 days from the date of shipment, if the product manufactured by us and sold by us (or an authorized distributor) is in the possession of the original buyer, we will replace or repair, at our option, free of charge, any part or parts which upon examination are found to be defective in workmanship or material, and not due to normal wear, provided that, upon our request, the product or parts thereof are returned to our location, with accompanying documentation that the product has been installed, used and maintained in accordance with instructions and has not been subject to abuse. We shall not be liable or responsible for any expense or liability for repairs, additions, or modifications made upon the product without our written consent. This warranty is in lieu of all other express or implied warranties (including without limitation any warranty of merchantability or fitness for a particular purpose.) In no event shall we be liable for any indirect, special, or consequential damages (including, but not limited to, lost profits or other damages from loss of production) caused by defective material, or by unsatisfactory performance of the product, or by any other breach of contract by us. The Elijah Tooling, Inc. Warranty shall apply in all cases to all products manufactured by us and sold by us. Elijah Tooling, Inc. reserves the right to modify or change the design of products shown in this specification/instruction sheet, without notice. Such modifications or changes may include, but are not limited to, changes in finish, materials, specifications, etc., from descriptions and illustrations of products listed herein.

Proviso: The Elijah Tooling Inc. ZipBushing™ Threaded Locator Bushing is not certified to any specification. USE AT YOUR OWN RISK. If loading is a concern, it will be necessary for you to perform your own load analysis prior to usage in an application.