

Your Elijah Tooling, Inc. T-Slot fastener has been manufactured to provide low cost, high value performance combined with ease of use. This fastener is a patent-pending product, ideal for connecting two materials or objects together in the context of a T-Slot fixture. Simply slide your fastener down the slot to where you wish to attach a part or tooling (or really anything with the proper thread) and bias the stud up to achieve superior work-holding capability. T-Slot fastener features finishes that improve appearance and reduce rust as well as providing closely held tolerances on threads and internal dimensions to insure that it meets your exacting expectations. Use of the O-Ring is optional. Quickly slide your finger or tool along the slot in the base to remove the O-Ring. With the O-Ring, the fastener "drags" along the T-Slot. Without the O-Ring, "sling" the fastener down the slot. Your choice!

Key Dimensional Information

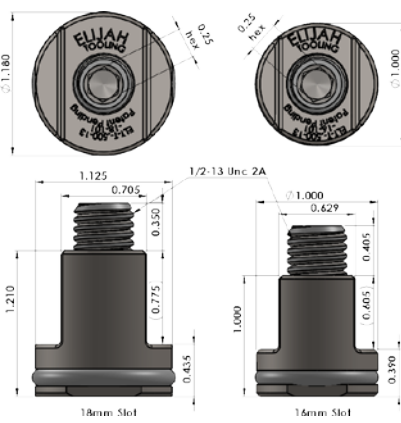

Cross-Sectional View of Universal T-Slot Fixture/ Application

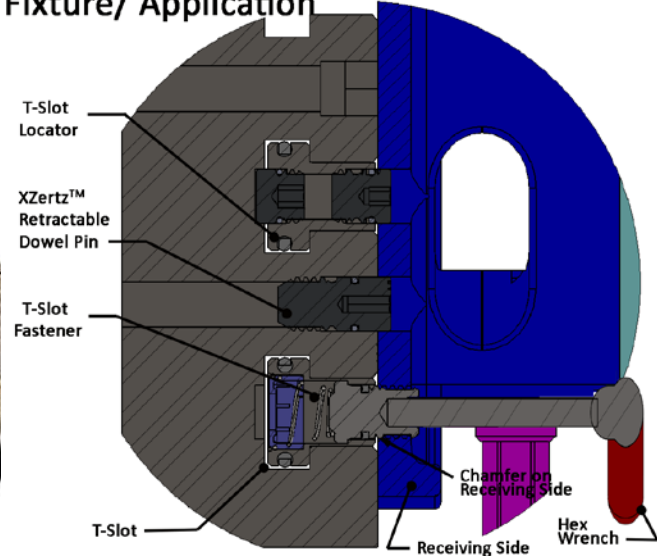

Fastener P/N: ELT-T-.500-13-16-101
1/2"-13 dia. Stud x 16mm Slot Fastener
.35 stud stickout, 1/4" hex



www.invert-a-bolt.com

LIMITED WARRANTY

We warrant that within 90 days from the date of shipment, if the product manufactured by us and sold by us (or an authorized distributor) is in the possession of the original buyer, we will replace or repair, at our option, free of charge, any part or parts which upon examination are found to be defective in workmanship or material, and not due to normal wear, provided that, upon our request, the product or parts thereof are returned to our location, with accompanying documentation that the product has been installed, used and maintained in accordance with instructions and has not been subject to abuse. We shall not be liable or responsible for any expense or liability for repairs, additions, or modifications made upon the product without our written consent.

This warranty is in lieu of all other express or implied warranties (including without limitation any warranty of merchantability or fitness for a particular purpose.) In no event shall we be liable for any indirect, special, or consequential damages (including, but not limited to, lost profits or other damages from loss of production) caused by defective material, or by unsatisfactory performance of the product, or by any other breach of contract by us.

The Elijah Tooling, Inc. Warranty shall apply in all cases to all products manufactured by us and sold by us. Elijah Tooling, Inc. reserves the right to modify or change the design of products shown in this specification/instruction sheet, without notice. Such modifications or changes may include, but are not limited to, changes in finish, materials, specifications, etc., from descriptions and illustrations of products listed herein.

Proviso: The T-Slot fastener is not certified to any specification. If loading is a concern, you should perform your own load analysis prior to usage in an application. In no case will Elijah Tooling Inc. be liable for any damages, incidental or otherwise as a result of applying greater loads than capable of this device. The T-Slot fastener should be used in only two positions – the stud is fully engaged or fully dis-engaged.

Usage of the T-Slot fastener is quite simple. Slide the fastener into place and, placing your hex wrench through the receiving side, bias the stud into the piece to be held. Torque as shown below.

Prepare the "receiving" side to accept the stud threads:

Tap Drill 27/64" diameter thru. C'sink .60" dia. x 45 degrees. Tap 1/2"-13 .45" deep.

For better resistance against vibration, use a Spirallock® tap. Once the "receiving" side has been prepped, place the "receiving" side 1/2"-13 tapped hole directly above the T-Slot fastener. Reach through the 1/2"-13 hole with your hex head wrench until contacting the hex head broach in the stud. Start turning counter-clockwise lifting your hex head wrench at the same time. The stud will proceed into the 1/2"-13 tapped hole. Tighten until the stud is fully engaged (approximately .40 inches into the "receiving" side) at 35 ft.lbs. Use a feeler gauge to insure that the "receiving" side material is pulled down properly.